

# Analog Devices Welcomes Hittite Microwave Corporation

NO CONTENT ON THE ATTACHED DOCUMENT HAS CHANGED



**THIS PAGE INTENTIONALLY LEFT BLANK**

**1 dB LSB GaAs MMIC 5-BIT SERIAL CONTROL DIGITAL ATTENUATOR, 0.7 - 3.7 GHz**
**Typical Applications**

The HMC271LP4 / HMC271LP4E is ideal for:

- Cellular/3G Infrastructure
- Fixed Wireless, WiMax & WiBro
- Test Instrumentation

**Features**

- 1 dB LSB Steps to 31 dB
- CMOS Compatible Serial Data Interface
- SPI Compatible Serial Output
- ±0.4 dB Typical Bit Error
- 24 Lead 4x4mm QFN Package: 16mm<sup>2</sup>
- Included in the HMC-DK004 Designer's Kit

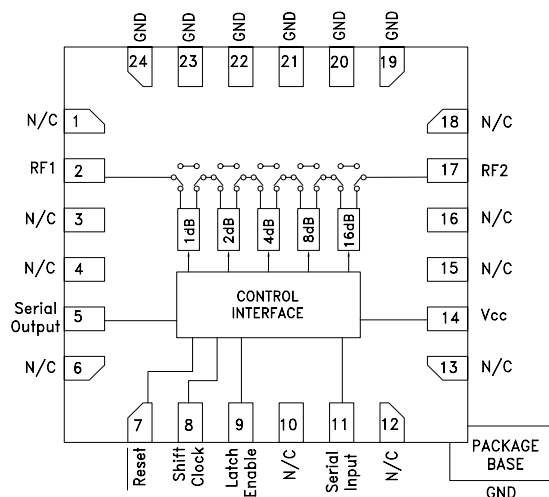
**Functional Diagram**

**General Description**

The HMC271LP4 & HMC271LP4E are broadband 5-bit positive control GaAs IC digital attenuators with CMOS compatible serial-to-parallel drivers in low cost leadless QFN 4x4 mm SMT packages. Covering 0.7 to 3.7 GHz, the insertion loss is typically less than 2.5 dB. The attenuator bit values are 1 (LSB), 2, 4, 8, and 16 dB for a total attenuation of 31 dB. Accuracy is excellent at ± 0.4 dB typical with an IIP3 of up to +48 dBm. Five bit CMOS compatible serial control words are used to select each attenuation state. A single Vcc bias of +3V to +5V applied through an external 5k Ohm resistor is required.

**Electrical Specifications,  $T_A = +25^\circ\text{C}$ ,  $V_{CC} = +3\text{V to } +5\text{V}$** 

Parameter	Frequency	Min.	Typical	Max.	Units
Insertion Loss	0.7 - 1.4 GHz		1.9	2.4	dB
	1.4 - 2.3 GHz		2.3	2.8	dB
	2.3 - 2.7 GHz		2.6	3.1	dB
	2.7 - 3.7 GHz		2.8	3.3	dB
Attenuation Range	0.7 - 3.7 GHz		31		dB
Return Loss (RF1 & RF2, All Atten. States)	0.7 - 1.4 GHz		12		dB
	1.4 - 2.7 GHz		15		dB
	2.7 - 3.7 GHz		16		dB
Attenuation Accuracy: (Referenced to Insertion Loss) All Attenuation States	0.7 - 0.9 GHz	± (0.4 + 5% of Atten. Setting) Max			dB
	0.9 - 2.2 GHz	± (0.4 + 4% of Atten. Setting) Max			dB
	2.2 - 3.7 GHz	± (0.4 + 5% of Atten. Setting) Max			dB
Input Power for 0.1 dB Compression	0.7 - 3.7 GHz	$V_{CC} = 5\text{V}$	24		dBm
		$V_{CC} = 3\text{V}$	22		dBm
Input Third Order Intercept Point (Two-tone Input Power = 0 dBm Each Tone)	0.7 - 3.7 GHz	$V_{CC} = 5\text{V}$	48		dBm
		$V_{CC} = 3\text{V}$	46		dBm
Switching Characteristics					
tRISE, tFALL (10/90% RF)	0.7 - 3.7 GHz		750		ns
tON, tOFF (Latch Enable to 10/90% RF)			830		ns



**1 dB LSB GaAs MMIC 5-BIT SERIAL CONTROL DIGITAL ATTENUATOR, 0.7 - 3.7 GHz**

**Insertion Loss**

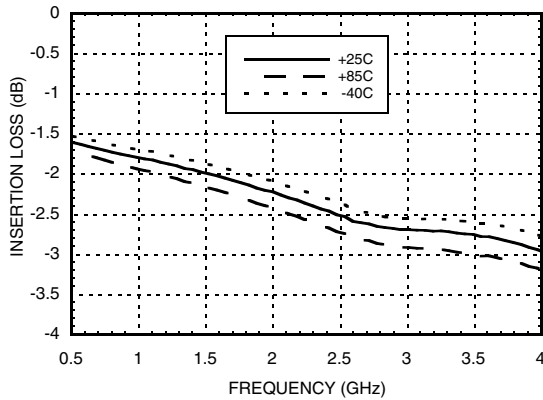

**Return Loss RF1, RF2**  
 (Only Major States are Shown)

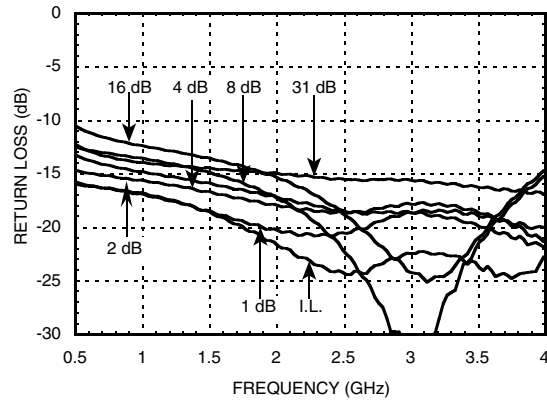

**Normalized Attenuation**  
 (Only Major States are Shown)

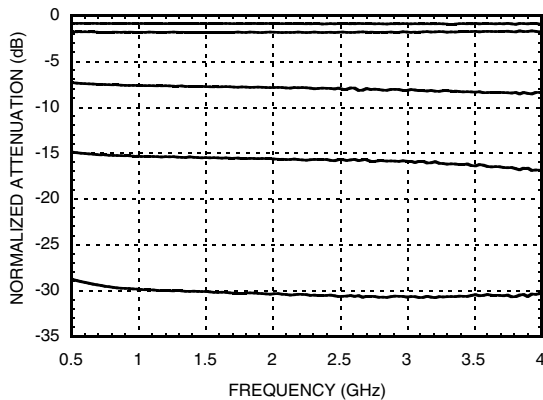

**Bit Error vs. Attenuation State**

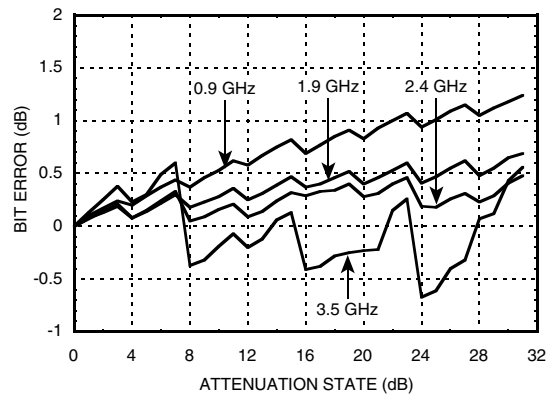

**Bit Error vs. Frequency**  
 (Only Major States are Shown)

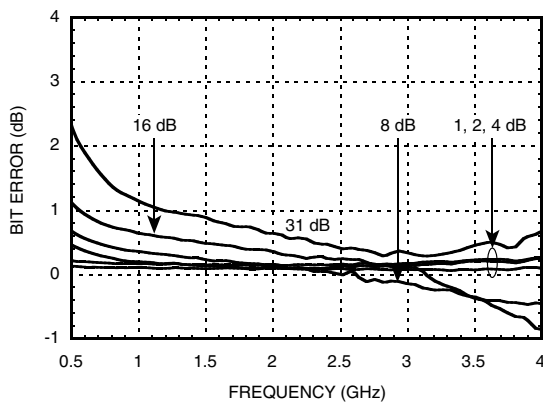

**Relative Phase vs. Frequency**  
 (Only Major States are Shown)

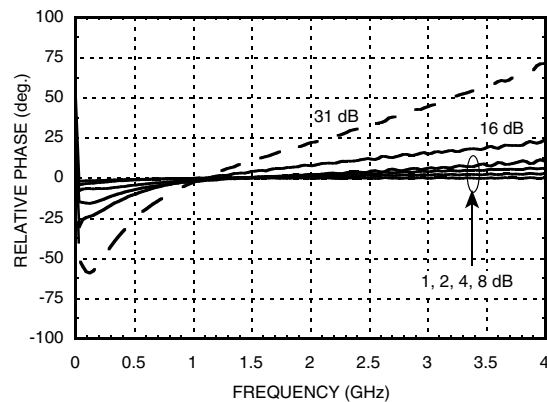

Note: All Data Typical Over Voltage (+3V to +5V) & Temperature (-40 to +85 deg. C.).



**1 dB LSB GaAs MMIC 5-BIT SERIAL CONTROL DIGITAL ATTENUATOR, 0.7 - 3.7 GHz**

**Worst Case Step Error Between Successive Attenuation States**

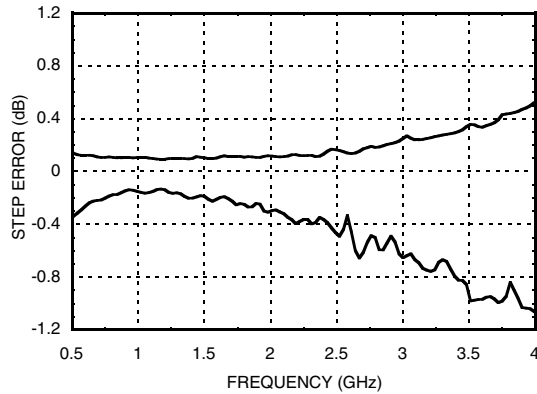

**Digital Control Voltages**

State	Vcc = +5V	Vcc = +3V
Low	0 to 1.3V	0 to 0.7V
High	3.5 to 5V	2.3 to 3V

**Serial Input Truth Table**

Latch Enable	Shift Clock	Reset	Function
X	X	L	Shift register cleared
X	↑	H	Shift register clocked
↑	X	H	Contents of shift register transferred to Digital Attenuator

**Timing**

Parameter	Symbol	Vcc = +5V		Vcc = +3V		Units
		Min.	Max.	Min.	Max.	
Serial Input Setup Time	ts	20	-	100	-	ns
Hold time from Serial Input to Shift Clock	th	0	-	5	-	ns
Setup time from Shift Clock to Latch Enable	tlsup	40	-	100	-	ns
Propagation delay, Latch Enable to C1 through C16	tpd	-	30	-	70	ns
Setup time from Reset to Shift Clock	-	20	-	50	-	ns
Clock Frequency (1/tclk)	fclk	-	30	-	10	MHz

**Truth Table**

Serial Data Input					Attenuation Setting RF1 - RF2
C1	C2	C4	C8	C16	
High	High	High	High	High	Reference I.L.
Low	High	High	High	High	1 dB
High	Low	High	High	High	2 dB
High	High	Low	High	High	4 dB
High	High	High	Low	High	8 dB
High	High	High	High	Low	16 dB
Low	Low	Low	Low	Low	31 dB Max. Atten.

Any combination of the above states will provide an attenuation approximately equal to the sum of the bits selected.

**Timing Diagram**

Serial data is shifted in on the rising edge of the Shift Clock, LSB first, and is latched on the rising edge of Latch Enable.

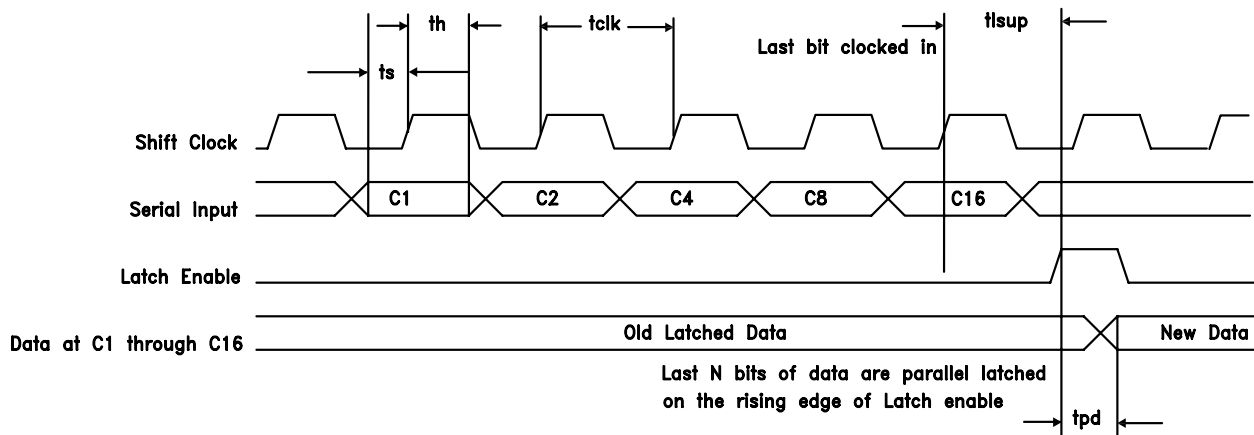

**1 dB LSB GaAs MMIC 5-BIT SERIAL CONTROL DIGITAL ATTENUATOR, 0.7 - 3.7 GHz**

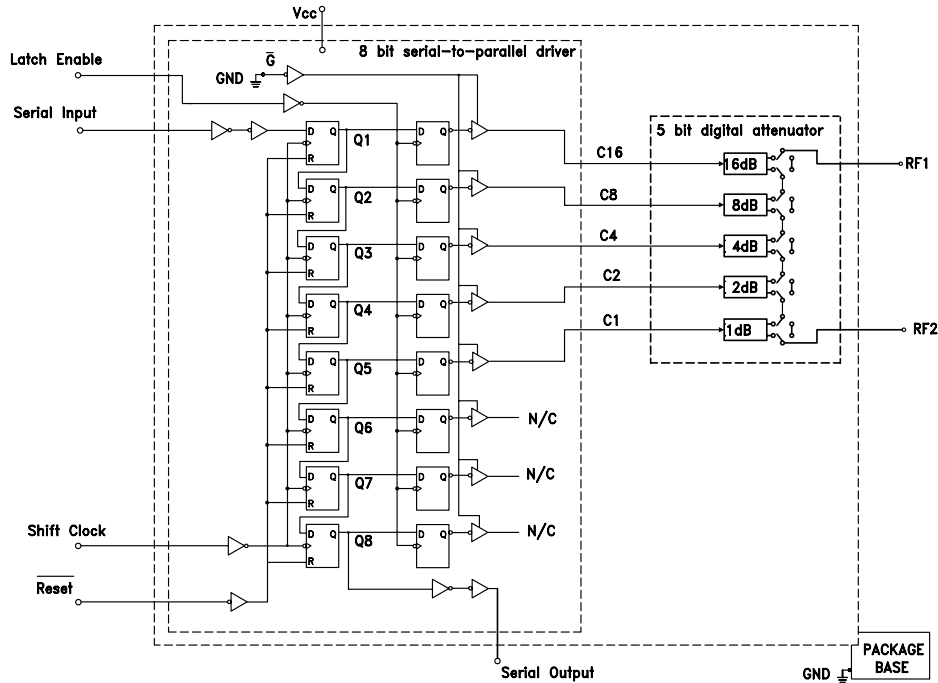

**Logic / Functional Diagram**

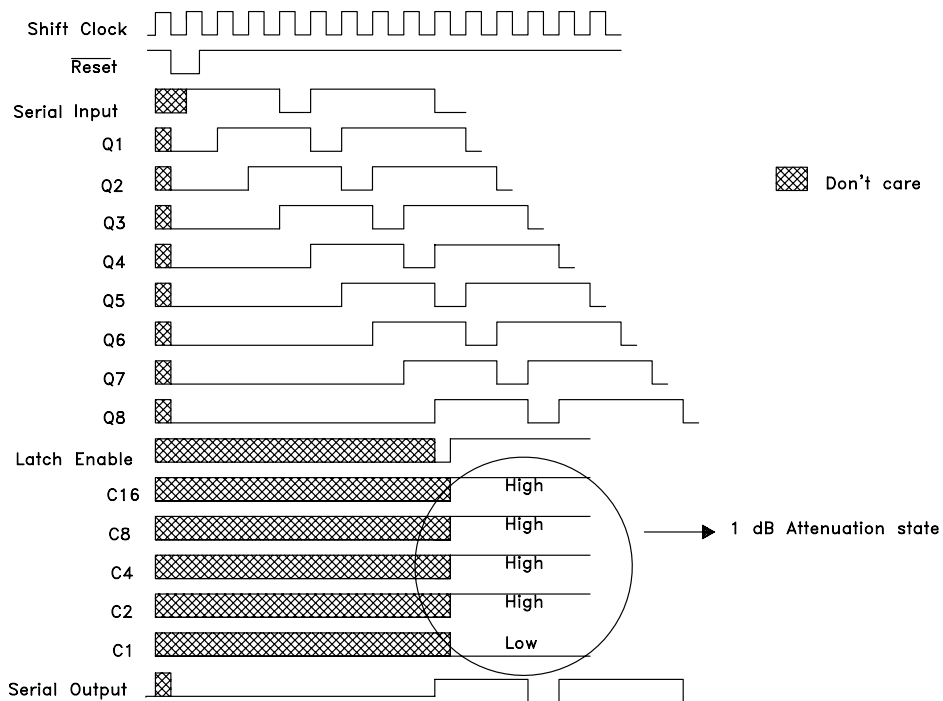

**Programming Example to Select 1 dB Attenuation State**



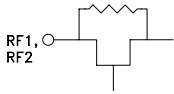
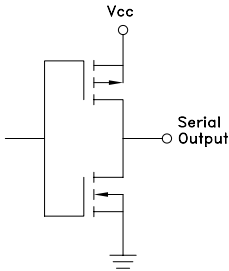
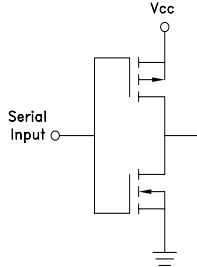

**1 dB LSB GaAs MMIC 5-BIT SERIAL CONTROL DIGITAL ATTENUATOR, 0.7 - 3.7 GHz**
**Pin Descriptions**

Pin Number	Function	Description	Interface Schematic
1, 3, 4, 6, 10, 12, 13, 15, 16, 18	N/C	These pins should be connected to PCB RF ground to maximize performance.	
2, 17	RF1, RF2	This pin is DC coupled and matched to 50 Ohms. Blocking capacitors are required. Select value based on lowest frequency of operation.	
5	Serial Output	Serial data output. Serial input data delayed by 8 clock cycles.	
7	Reset	See truth table, control voltage table and timing diagram.	
8	Shift Clock		
9	Latch Enable		
11	Serial Input		
14	Vcc	Supply Voltage.	
19 - 24	GND	Package bottom has an exposed metal paddle that must also be connected to RF/DC Ground.	

**1 dB LSB GaAs MMIC 5-BIT SERIAL CONTROL DIGITAL ATTENUATOR, 0.7 - 3.7 GHz**

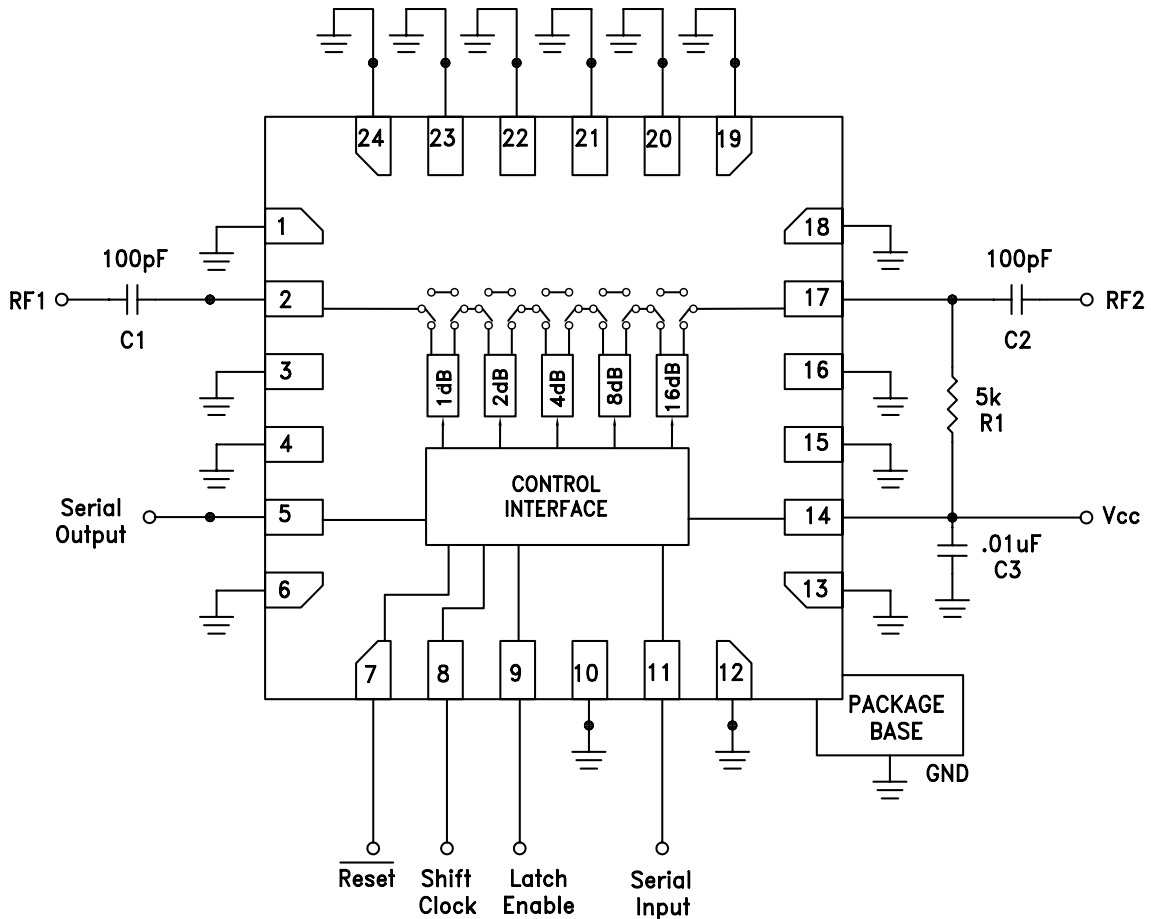
**Application Circuit**



DC blocking capacitors C1 & C2 are required on RF1 & RF2. Choose C1 = C2 = 100 ~ 300 pF to allow lowest customer specific frequency to pass with minimal loss. R1 = 5k Ohm is required to supply voltage to the circuit through either PIN 2 or PIN 17.





**1 dB LSB GaAs MMIC 5-BIT SERIAL CONTROL DIGITAL ATTENUATOR, 0.7 - 3.7 GHz**

**Absolute Maximum Ratings**

Digital Inputs (Reset, Shift Clock, Latch Enable & Serial Input)	-1.5 to (Vcc + 1.5) V
Digital Outputs (Serial Output)	-0.5 to (Vcc + 0.5) V
DC Current on Serial Output	±35 mA
Bias Voltage (Vcc)	+7V
Storage Temperature	-65 to +150 °C
Operating Temperature	-40 to +85 °C
RF Input Power (0.7 - 3.7 GHz)	+26 dBm
ESD Sensitivity (HBM)	Class 1A



**ELECTROSTATIC SENSITIVE DEVICE  
OBSERVE HANDLING PRECAUTIONS**

**Outline Drawing**

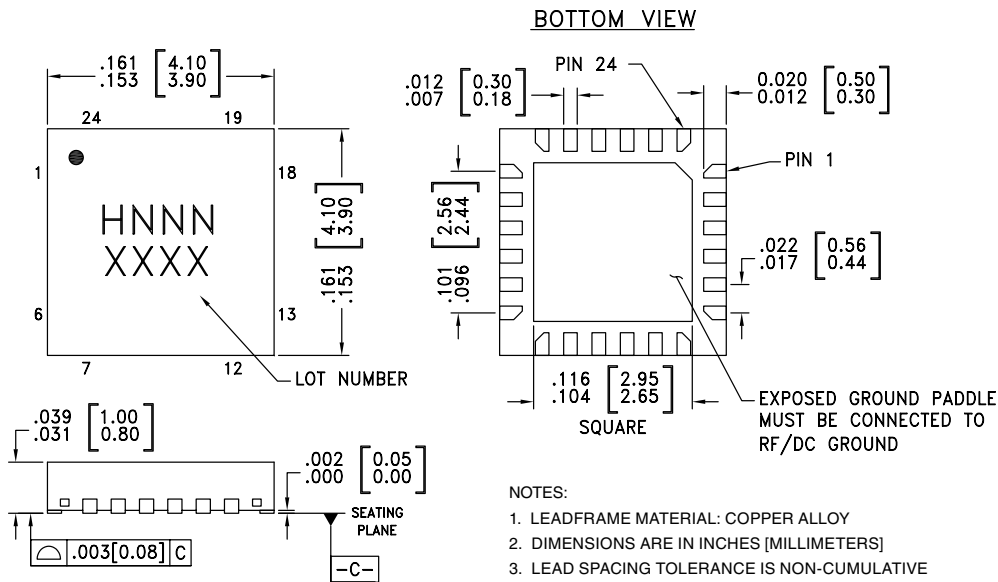

**Package Information**

Part Number	Package Body Material	Lead Finish	MSL Rating	Package Marking <sup>[3]</sup>
HMC271LP4	Low Stress Injection Molded Plastic	Sn/Pb Solder	MSL1 <sup>[1]</sup>	H271 XXXX
HMC271LP4E	RoHS-compliant Low Stress Injection Molded Plastic	100% matte Sn	MSL1 <sup>[2]</sup>	H271 XXXX

[1] Max peak reflow temperature of 235 °C

[2] Max peak reflow temperature of 260 °C

[3] 4-Digit lot number XXXX

**1 dB LSB GaAs MMIC 5-BIT SERIAL CONTROL DIGITAL ATTENUATOR, 0.7 - 3.7 GHz**

**Evaluation Circuit Board**

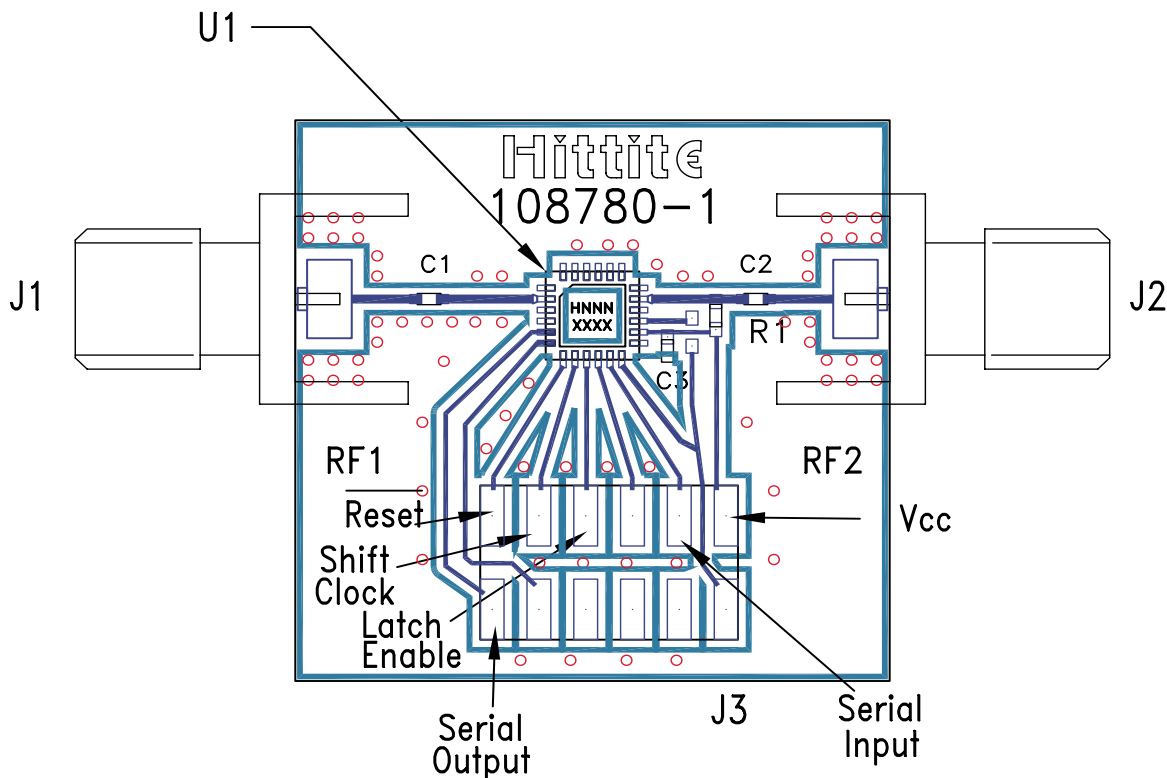

**List of Materials for Evaluation PCB 108782 [1]**

Item	Description
J1 - J2	PCB Mount SMA Connector
J3	2 mm Molex Header
C1, C2	100 pF Capacitor, 0402 Pkg.
C3	0.01 $\mu$ F Capacitor, 0402 Pkg.
R1	5k Ohm Resistor, 0402 Pkg.
U1	HMC271LP4(E) Digital Attenuator
PCB [2]	108780 Evaluation PCB

[1] Reference this number when ordering complete evaluation PCB

[2] Circuit Board Material: Rogers 4350

The circuit board used in the application should use RF circuit design techniques. Signal lines should have 50 Ohm impedance while the package ground leads and exposed ground paddle should be connected directly to the ground plane similar to that shown below. A sufficient number of via holes should be used to connect the top and bottom ground planes. The evaluation circuit board as shown is available from Hittite Microwave Corporation upon request.